

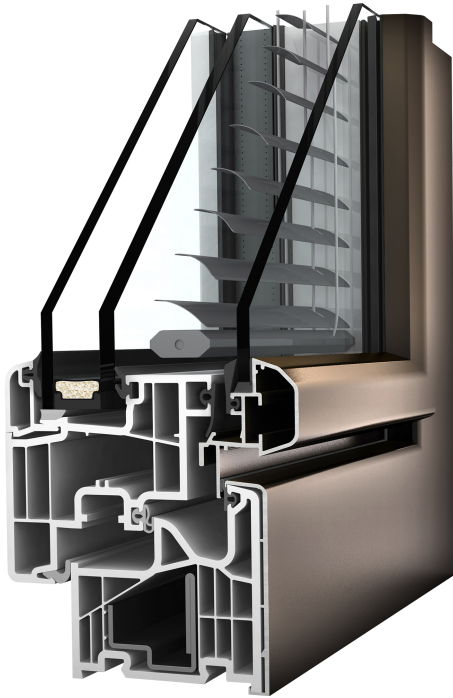





# KV 350 UPVC-ALUMINIUM-COMPOSITE WINDOW





## CHARACTERISTICS

 **Thermal insulation** (in W/m<sup>2</sup>K)  
U<sub>w</sub> up to 0,79

 **Sound reduction** (in dB)  
up to 38 - 44

 **Security**  
up to RC 2

 **Locking**  
fully concealed

 **Installation Depth** (in mm)  
74

**I-tec Glazing**

**I-tec Shading**

**I-tec Connect**

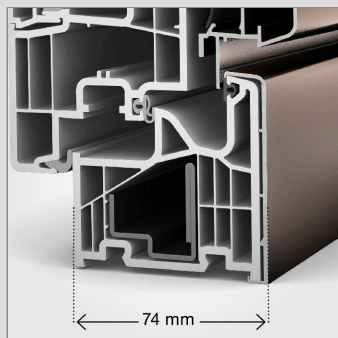
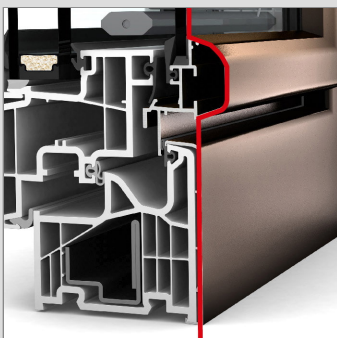

Despite the profiled edges of the window sash and frame, the KV 350 composite window has a very narrow design. Four additional advantages are hidden within this window: In addition to optimum sound and thermal insulation, the sun and privacy protection is also integrated directly into the window. This not only has advantages when cleaning, as the blinds are protected from wind, weather and dirt by the glass panes. You no longer have to do without sun protection, even with renovations or façades where shutters are not permitted. I-tec Shading with photovoltaic module and rechargeable battery is completely energy self-sufficient and also offers many useful functions.



**Cuts**

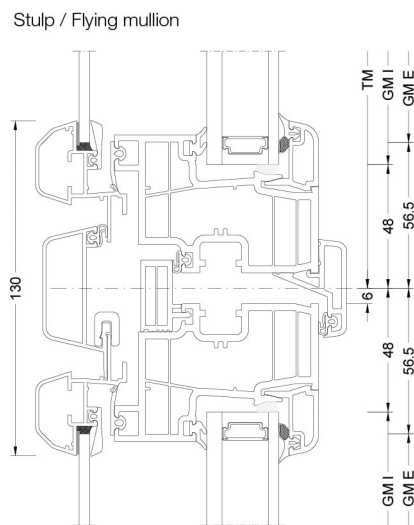
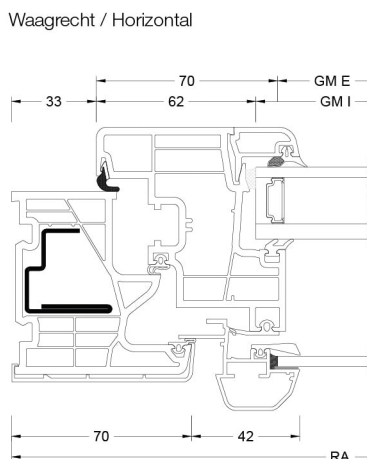
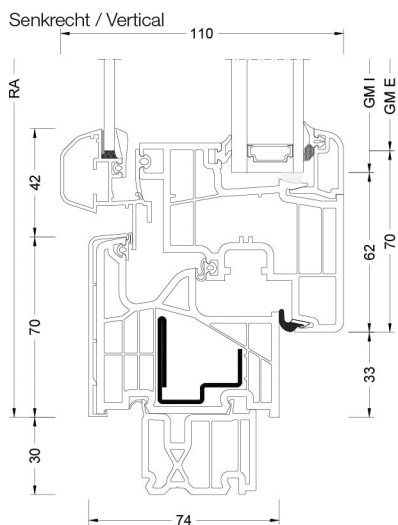

BM Bestellmaß / Ordering size  
 FM G Flügelmaß Gehflügel / Sash size master sash  
 FM S Flügelmaß Stehflügel / Sash size slave sash  
 FOK Fußbodenoberkante / Finished floor level

GM Glasmaß / Glass size  
 RA Rahmenaußenmaß / Outside frame size  
 TM Teilungsmaß / Division size

**Values**

Glass Build Up	GC	Coating	AH	U <sub>g</sub>	g	U <sub>f</sub>	Psi	U <sub>w</sub>	R <sub>w</sub>	C	Ctr	Certificate - Thermal Performance	Certificate - Sound
4 // 6/18Ar/b4	2KU	Low-Carbon iplus	Iso Alu	1,1 1,1	- -	1,1 1,1	0,028 0,047	1,0 1,1	40 40	-2 -2	-9 -9	✓ ✓	✓ ✓
6 // 6/18Ar/b4	2KU	Low-Carbon iplus	Iso Alu	1,1 1,1	- -	1,1 1,1	0,028 0,047	1,0 1,1	42 42	-3 -3	-9 -9	✓ ✓	✓ ✓
4 // 3bESG/10Kr/ 2TVG/10Kr/ b3ESG	37F	Low-Carbon iplus	Iso Alu	0,6 0,6	- -	1,1 1,1	0,033 0,052	0,79 0,84	38 38	- -	- -	✓ ✓	✗ ✗
6 // 3bESG/10Kr/ 2TVG/10Kr/ b3ESG	37F	Low-Carbon iplus	Iso Alu	0,6 0,6	- -	1,1 1,1	0,033 0,052	0,79 0,84	40 40	- -	- -	✓ ✓	✗ ✗

**ECLAZ®** – Enjoy the many benefits of the Internorm **ECLAZ® Premium Coating****More light & transparency**

- The special coating allows more daylight to enter the interior, therefore making it brighter and friendlier.
- Enjoy a clearer view of the outside. The external reflection or mirror effect is also low and the glass is colour-neutral from the outside.

**Improved health & productivity**

- ECLAZ® helps to regulate your inner balance. Blue light from the sun helps to regulate your natural sleep and wake cycle, elevate moods and increase the feeling of well being.

**Increased happiness & well-being**

- Daylight has a balanced light spectrum and regulates the serotonin balance, which is responsible for well-being and life energy. Halogen bulbs, fluorescent tubes and LEDs lack these important light frequencies. ECLAZ® floods the house with daylight.

- 77% more light transmission of triple glazing with ECLAZ® helps to boost health and well-being, especially in the darker autumn and winter months.

**Better energy efficiency & higher cost savings**

- Less heat loss: ECLAZ® provides excellent thermal insulation, therefore reducing heating costs.
- Greater energy savings: 60% improvement in solar gain with triple glazing resulting in lower heating costs and higher energy efficiency.

**Get more as standard**

- ECLAZ® is fitted as standard in every Internorm window.
- No additional costs. You enjoy the benefits of this premium glass coating without having to pay more.



# KV 350 UPVC-ALUMINIUM-COMPOSITE WINDOW



## CHARACTERISTICS



**Thermal insulation** (in  $W/m^2K$ )  
 $U_w$  up to 0,79



**Sound reduction** (in dB)  
up to 38 - 44



**Security**  
up to RC 2



**Locking**  
fully concealed



**Installation Depth** (in mm)  
74

**I-tec Glazing**

**I-tec Shading**

**I-tec Connect**

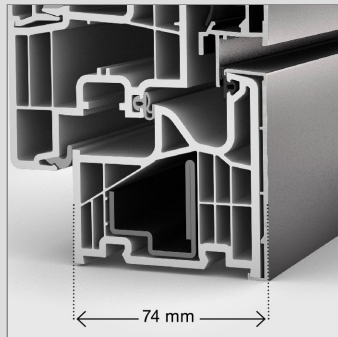
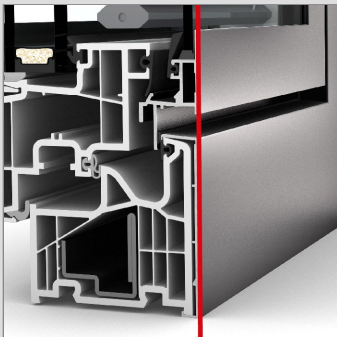

The modern and narrow KV 350 composite window conceals four advantages. In addition to optimum sound and heat insulation, the sun and privacy protection is also integrated directly into the window. This not only has advantages when cleaning, as the blinds are protected from wind, weather and dirt by the glass panes. You no longer have to do without sun protection, even with renovations or façades where shutters are not permitted. I-tec Shading with photovoltaic module and rechargeable battery is completely energy self-sufficient and also offers many useful functions.



**Cuts**

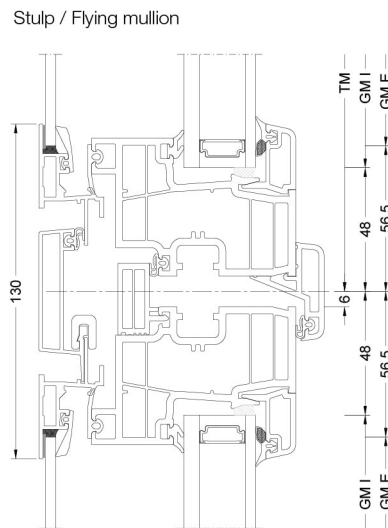
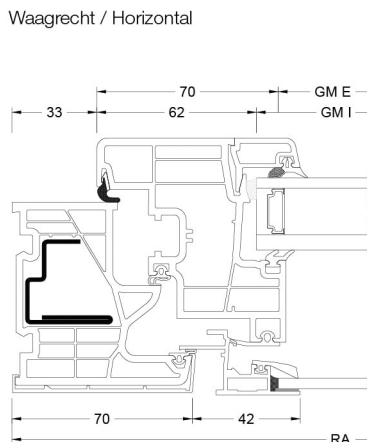
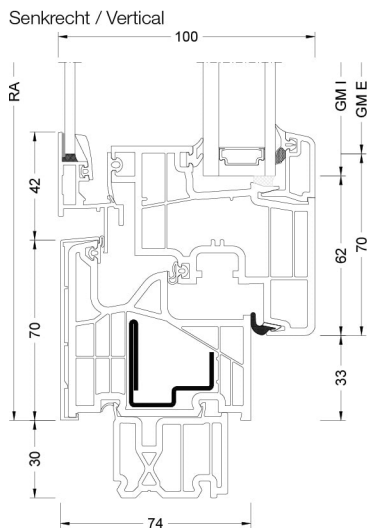

BM Bestellmaß / Ordering size  
 FM G Flügelmaß Gehflügel / Sash size master sash  
 FM S Flügelmaß Stehflügel / Sash size slave sash  
 FOK Fußbodenoberkante / Finished floor level

GM Glasmaß / Glass size  
 RA Rahmenaußenmaß / Outside frame size  
 TM Teilungsmaß / Division size

**Values**

Glass Build Up	GC	Coating	AH	U <sub>g</sub>	g	U <sub>f</sub>	Psi	U <sub>w</sub>	R <sub>w</sub>	C	Ctr	Certificate - Thermal Performance	Certificate - Sound
4 // 6/18Ar/b4	2KU	Low-Carbon iplus	Iso Alu	1,1 1,1	- -	1,1 1,1	0,028 0,047	1,0 1,1	40 40	-2 -2	-9 -9	✓ ✓	✓ ✓
6 // 6/18Ar/b4	2KU	Low-Carbon iplus	Iso Alu	1,1 1,1	- -	1,1 1,1	0,028 0,047	1,0 1,1	42 42	-3 -3	-9 -9	✓ ✓	✓ ✓
4 // 3bESG/10Kr/ 2TVG/10Kr/ b3ESG	37F	Low-Carbon iplus	Iso Alu	0,6 0,6	- -	1,1 1,1	0,033 0,052	0,79 0,84	38 38	- -	- -	✓ ✓	✗ ✗
6 // 3bESG/10Kr/ 2TVG/10Kr/ b3ESG	37F	Low-Carbon iplus	Iso Alu	0,6 0,6	- -	1,1 1,1	0,033 0,052	0,79 0,84	40 40	- -	- -	✓ ✓	✗ ✗

**ECLAZ®** – Enjoy the many benefits of the Internorm **ECLAZ® Premium Coating****More light & transparency**

- The special coating allows more daylight to enter the interior, therefore making it brighter and friendlier.
- Enjoy a clearer view of the outside. The external reflection or mirror effect is also low and the glass is colour-neutral from the outside.

**Improved health & productivity**

- ECLAZ® helps to regulate your inner balance. Blue light from the sun helps to regulate your natural sleep and wake cycle, elevate moods and increase the feeling of well being.

**Increased happiness & well-being**

- Daylight has a balanced light spectrum and regulates the serotonin balance, which is responsible for well-being and life energy. Halogen bulbs, fluorescent tubes and LEDs lack these important light frequencies. ECLAZ® floods the house with daylight.

- 77% more light transmission of triple glazing with ECLAZ® helps to boost health and well-being, especially in the darker autumn and winter months.

**Better energy efficiency & higher cost savings**

- Less heat loss: ECLAZ® provides excellent thermal insulation, therefore reducing heating costs.
- Greater energy savings: 60% improvement in solar gain with triple glazing resulting in lower heating costs and higher energy efficiency.

**Get more as standard**

- ECLAZ® is fitted as standard in every Internorm window.
- No additional costs. You enjoy the benefits of this premium glass coating without having to pay more.